

Typical Features

- ◆ Wide input voltage range 85-265VAC/120-380VDC
- ◆ No load power consumption $\leq 0.3W@220VAC$
- ◆ Efficiency 78% (Typ.)
- ◆ Operating temperature from $-40^{\circ}C$ to $+75^{\circ}C$
- ◆ Switching frequency 65KHz
- ◆ Short circuit & over current protections
- ◆ Isolation voltage 4000VAC
- ◆ Altitude during operation 4000m Max
- ◆ Compliant with IEC/EN62368/UL62368
- ◆ Enclosed plastic case, flame class UL94-V0
- ◆ PCB DIP mounting



Application Field

FA10-220E05XXE2D4 Series ----- Compact size, high efficiency modular power supplies with global adapted input voltage range (both AC & DC available), low ripple, low temperature raise, low standby power consumption, high efficiency, high reliability, safety isolated and good EMC performance. This series of products can be widely used in the fields of Electric power, Industrial, Instrument, Smart home devices, etc. The additional circuit diagram for EMC is recommended in this data sheet for the application with high EMC requirement.

Typical Product List

Certificate	Part No.	Output Specification					Max. Capacitive Load	Ripple & Noise(Max) 20MHz	Efficiency@ Full Load, 220VAC
		Power	Voltage	Current	Voltage	Current			
		(W)	Vo1(V)	Io1(mA)	Vo2(V)	Io2(mA)			
-	FA10-220E0505E2D4	10	5	1800	5	200	1000/470	80/100	75
	FA10-220E0512E2D4	10	5	1500	12	200	1000/470	80/100	78
	FA10-220E0524E2D4	10	5	1000	24	200	3000/170	80/120	83

Note 1: The typical value of efficiency is based on the product tested after half an hour burn-in at full load.

Note 2: The full load efficiency should be in $\pm 2\%$ of the typical value in this table. The efficiency is calculated by the way that the full output power is divided by the input power.

Note 3: Please contact Aipu sales for other output voltages requirements in this series but not in this table.

Input Specifications

Item	Operating Condition	Min.	Typ.	Max.	Unit
Input Voltage Range	AC Input	85	220	265	VAC
	DC Input	120	310	380	VDC

Input Frequency Range	-	47	50	63	Hz
Input Current	100VAC	-	-	0.25	A
	220VAC	-	-	0.13	
Surge Current	115VAC	-	-	10	A
	220VAC	-	-	20	
No-load Power Consumption	Input 115VAC	-	-	0.3	W
	Input 220VAC	-	-		
Leakage Current	-	0.5mA TYP/230VAC/50Hz			
External Fuse Recommended	-	1A-2A/250VAC Time-delay fuse			
Hot-plug	-	Unavailable			
Remote Control	-	Unavailable			

Output Specifications

Item		Operating Condition	Min.	Typ.	Max.	Unit
Voltage Accuracy	Full input voltage range Any load	Vo1	-	±2.0	±3.0	%
		Vo2	-	±2.0	±5.0	%
Line Regulation	Nominal Load	Vo1	-	-	±0.5	%
		Vo2	-	-	±1.5	%
Load Regulation	Nominal input voltage, 20%~100% load	Vo1	-	-	±2.0	%
		Vo2	-	-	±3.0	%
Minimum load	Single Output		0	-	-	%
	Dual outputs with common GND		10	-	-	%
	Dual outputs isolated		10	-	-	
Turn-on Delay Time	Input 115VAC (full load)		-	2500	-	mS
	Input 220VAC (full load)		-	1000	-	
Power-off Hold up Time	Input 115VAC (full load)		-	50	-	mS
	Input 220VAC (full load)		-	80	-	
Dynamic Response	Overshoot range	25%~50%~25%	-5.0	-	+5.0	%
	Recovery time	50%~75%~50%	-	5.0	-	mS
Output Overshoot	Full input voltage range	≤10%Vo			%	
Short Circuit Protection		Continuous, Self-recovery			Hiccup	
Drift Coefficient	-	-	±0.03%	-	%/°C	
Over Current Protection	Full input voltage range	≥120% Io, Self-recovery			Hiccup	
Ripple & Noise	-	-	-	120	mV	

Note: The Ripple and Noise are tested by the twisted pair method according to the test instruction in the datasheet.

General Specifications					
Item	Operating Condition	Min.	Typ.	Max.	Unit
Switching Frequency	-	-	65	-	KHz
Operating Temperature	Refer to the temperature derating graph	-40	-	+75	°C
Storage Temperature	-	-40	-	+85	°C
Soldering Temperature	Wave-soldering	260±4°C, timing 5-10S			
	Manual-soldering	360±8°C, timing 4-7S			
Relative Humidity	-	10	-	90	%RH
Isolation Voltage	I/P-O/P, Test 1min, leakage current ≤5mA	4000	-	-	VAC
Insulation Resistance	Input-Output@DC500V	100	-	-	MΩ
Safety Standard	-	EN623628, IEC623628			
Vibration	-	10-55Hz, 10G, 30Min, along X, Y, Z			
Safety Class	-	CLASS II			
Flame Class of Case	-	UL94 V-0			
MTBF	-	MIL-HDBK-217F@25°C > 300,000H			
Unit Weight	-	85g (Typ.)			

EMC Performances					
Total Item	Sub Item	Test Standard	Performance/Class		
EMC	EMI	CE	CISPR22/EN55032	CLASS B	
		RE	CISPR22/EN55032	CLASS B	
	EMS	RS	IEC/EN61000-4-3	10V/m	Perf.Criteria B (with the recommended circuit 1)
		CS	IEC/EN61000-4-6	3Vr.m.s	Perf.Criteria B (with the recommended circuit 1)
		ESD	IEC/EN61000-4-2	Contact ±6KV / Air ±8KV	Perf.Criteria B
		Surge	IEC/EN61000-4-5	±1KV	Perf.Criteria B
		EFT	IEC/EN61000-4-4	±2KV	Perf.Criteria B
		Voltage dips & interruptions	IEC/EN61000-4-11	0%~70%	Perf.Criteria B

Mechanical Dimensions

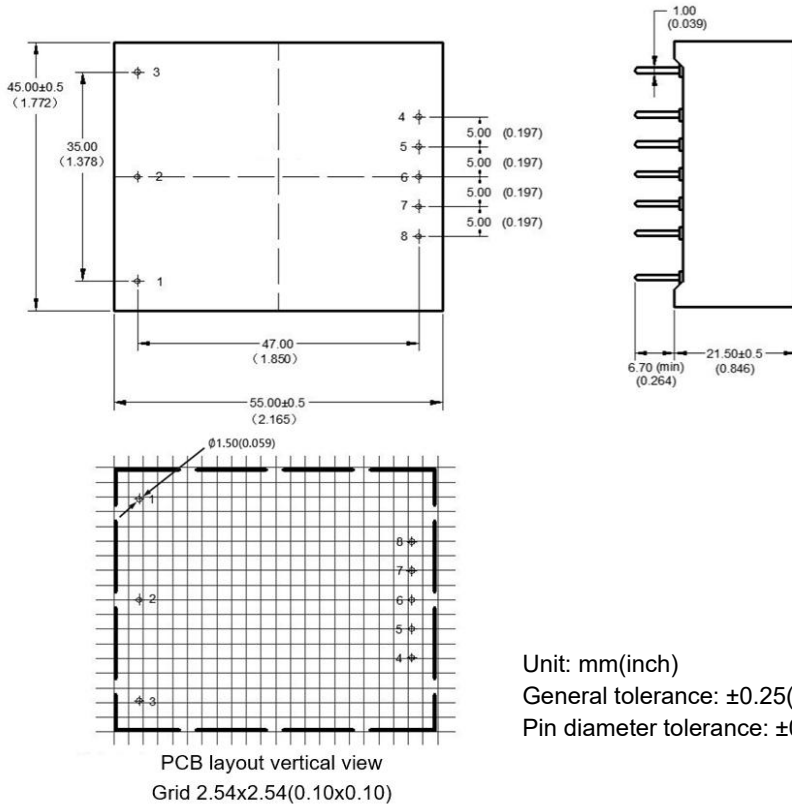

Pin No.	Function	
1	FG	No function
2	AC(N)	AC input (N)
3	AC(L)	AC input (L)
4	+Vo2	Output V2+
5	-Vo2	Output V2-
6	NP	No Pin
7	+Vo1	Output V1+
8	-Vo1	Output V1-

Unit: mm(inch)
 General tolerance: $\pm 0.25(\pm 0.010)$
 Pin diameter tolerance: $\pm 0.10(\pm 0.004)$

Package Code

E2

Dimensions L x W x H

55.00 x 45.00 x 21.50 mm

2.165 × 1.772 × 0.846 inch

Ripple & Noise Test Instruction (Twisted Pair Method, 20MHZ bandwidth)

1) The Ripple & noise test needs 12# twisted pair cables, an oscilloscope which bandwidth should be set to 20MHz, 0.1uF polypropylene capacitor and 10uF high-frequency low-resistance electrolytic capacitors are connected in parallel with the probes (100M bandwidth). The oscilloscope should be set at the Sample Mode.

2) The test diagram is shown on the right. The converter output connects to the electronic load by the jig with cables which size should be defined according to the output current value. The twisted pair (length 30cm±2 cm) should be connected in parallel with the load, the location is as close as possible to the output pins or terminals. The test can be start after input power on.

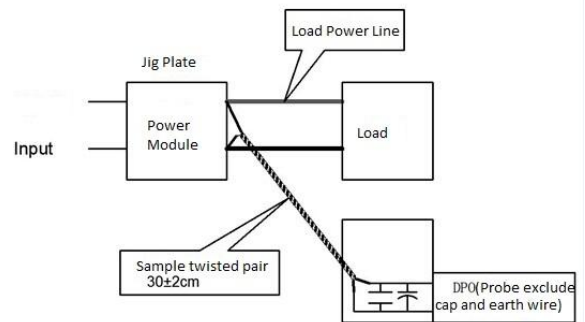

Product Characteristics Graphs

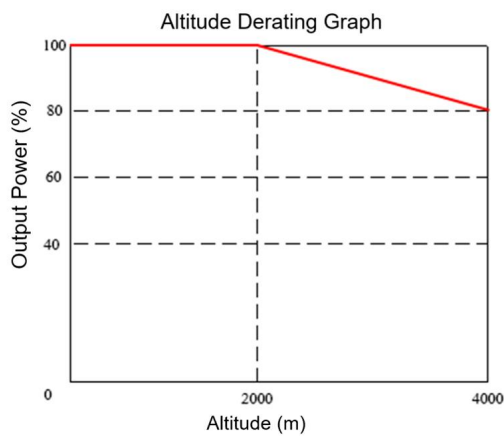
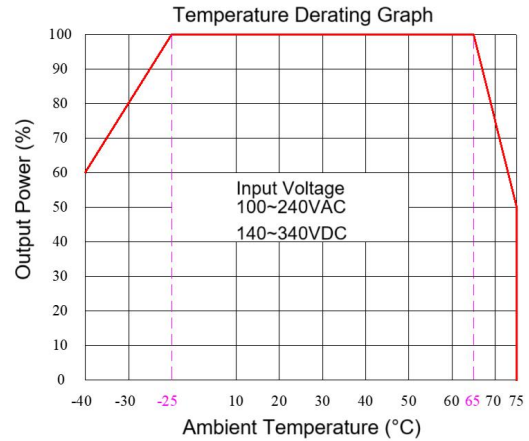
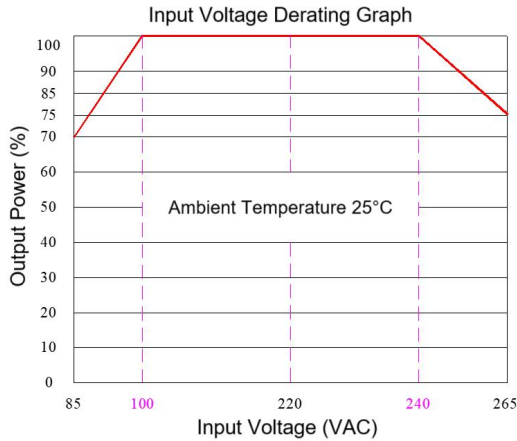

Note 1: The output power should be derated based on the input voltage derating graph at 85~100VAC/240~265VAC/120~140VDC/ 340~380VDC.

Note 2: This product should operate at the nature air condition, please contact us if it need be used at a closed space.

Recommended Typical EMC Circuit Diagram

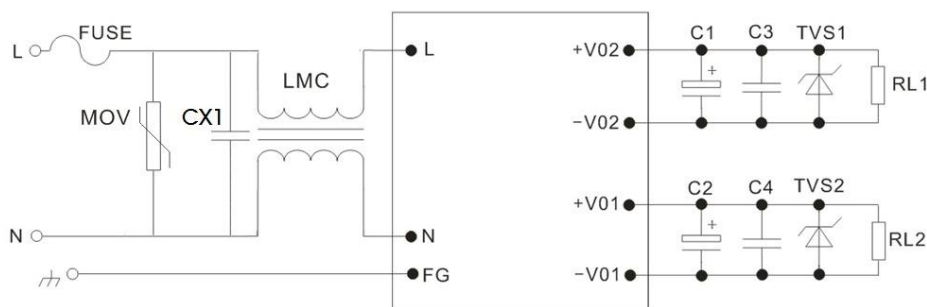

Figure – Circuit 1

Note:

- 1) 2A/250VAC time-delay fuse is recommended.
- 2) LMC is a Common mode choke, above 30mH/0.5A is recommended.
- 3) X2 capacitor (X2/224K/275VAC) is recommended for CX1.
- 4) 10D511K/3500A is recommended for MOV.
- 5) High frequency low impedance electrolytic capacitors are recommended for C1 & C2 with capacitance less than the Max capacitive load and withstand voltage >1.5x of the output voltage.
- 6) 0.1uF ceramic SMD capacitors are recommended for C3 & C4 which withstand voltage >1.5x of the output voltage.

7) TVS1 & TVS2: SMBJ7.0A for 5V output, SMBJ12.0A for 9V output, SMBJ20A for 12V & 15V outputs, SMBJ30.0A for 24V output, SMBJ64A for 48V output.

Application Notice

1. The products should be used according to the specifications in this datasheet, otherwise it could be permanently damaged.
2. A fuse should be connected at input.
3. The product performance in this datasheet cannot be guaranteed if it works at a lower load than the minimum load defined.
4. The product performance in this datasheet cannot be guaranteed if it works at over-load condition.
5. Unless otherwise specified, all values or indicators in this datasheet are tested at $T_a=25^{\circ}\text{C}$, humidity < 75%RH, nominal input voltage and rated load (pure resistance load).
6. All values or indicators in this datasheet had been tested based on Aipupower test specifications.
7. The specifications are specially for the parts listed in this datasheet, any other non-standard model performances could be out of the specifications. Please contact our technician for specific requirements.
8. Aipupower can provide customization service.

Guangzhou Aipu Electron Technology Co., Ltd

Address: Building 4, HEDY Park, No.63, Punan Road, Huangpu Dist, Guangzhou, China.

Tel: 86-20-84206763 Fax: 86-20-84206762 HOTLINE: 400-889-8821

E-mail: sales@aipu-elec.com Website: [https:// www.aipupower.com](https://www.aipupower.com)